

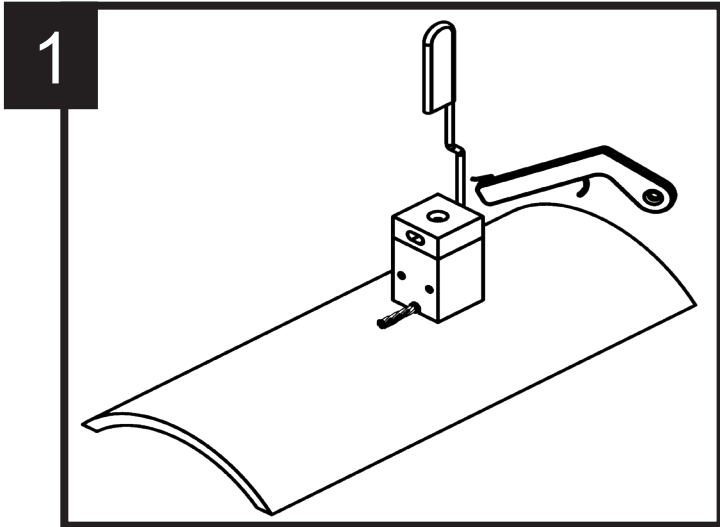

Applying a thermOcap is an easy 4 step process that protects against corrosion.

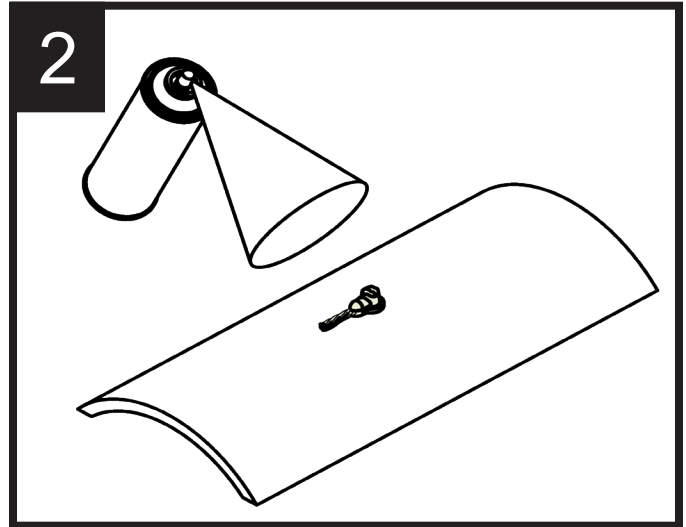

1  
Make your exothermic connection using thermOweld® brand welding products.



2  
Apply primer to weld and pipe to allow for improved performance.

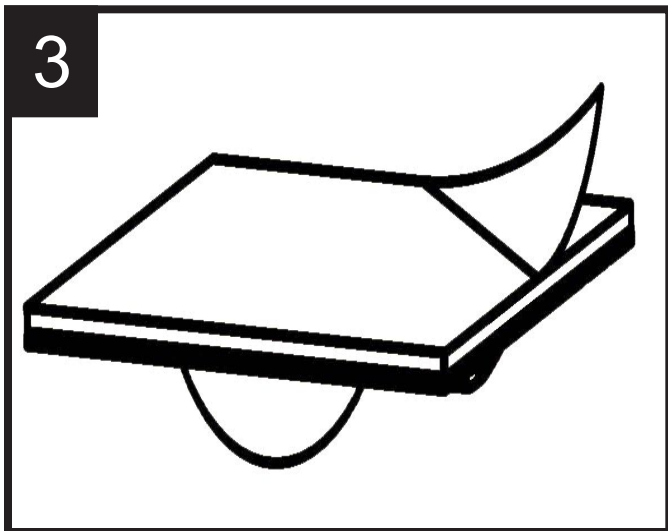

3  
Peel backing from the thermOcap using the attached tag.

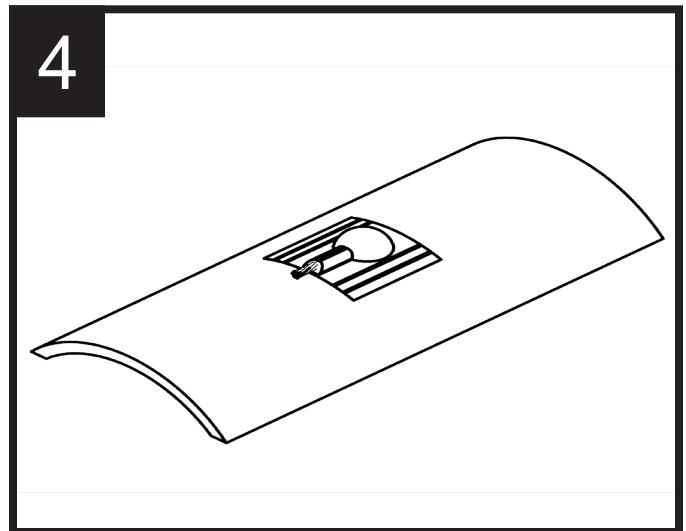

4  
Apply the thermOcap to the pipe by pressing firmly on all edges to insure a proper connection.